



## MC

The MC models of the M Series come in a 90° worksurface with the option of 3 floor base designs. This height adjustable table is a perfect fit for a corner or a pod layout, which combines 3-4 tables. Available with multiple weight capacities and worksurface sizes, the variety of color combinations make designing an MC table a unique & creative experience.

**Height Range:** 27.5" - 44"

**Weight Capacity:** 35 - 105 Lbs\*

**Worksurface Angle:** 90°

**Adjustability:** Constantforce

**Parts Warranty:** 10 years

**Craftsmanship Warranty:** Lifetime

**Special Feature:** Safety brake with integrated locking mechanism

*\*Varies based on column weight capacity*

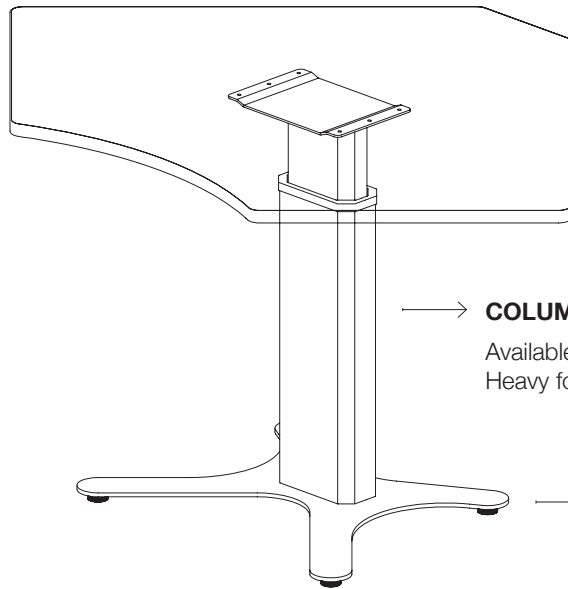

**WORKSURFACE**

MC Models are available with a 90° worksurface angle in multiple sizes.

**COLUMN**

Available in Ultra Light, Light, Medium and Heavy for multiple weight capacities.

**BASE**

Available in 3 base designs with the option of casters or glides.

**MODEL & FLOOR BASE SELECTION**

Choose your dimensions and and floor base design.

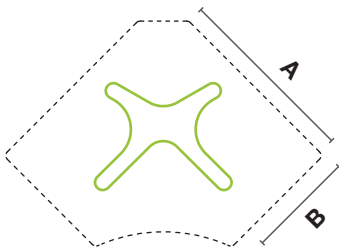

**LC** Large Clover

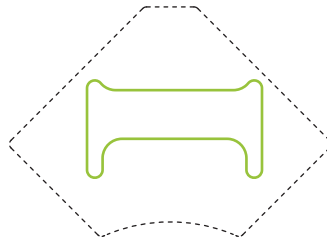

**H** Organic H

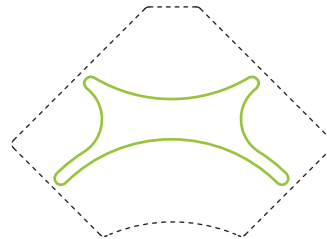

**BW** Bow Tie

**A** Range = 36" - 48"  
**B** Range = 24" - 30"

*Please speak with your Sales Rep for additional worksurface dimensions and specifications.*

**WORKSURFACE AVERAGE TASK LOAD**

Select all that apply.



**5-7 LBS**



**5-10 LBS**



**12-15 LBS**



**18-20 LBS**

**FRAME FINISHES**

Custom finishes require testing & longer lead times.



**S** Silver



**B** Black



**W** White

**COLUMN SELECTION**

Top weight is determined by size of worksurface. See price chart.

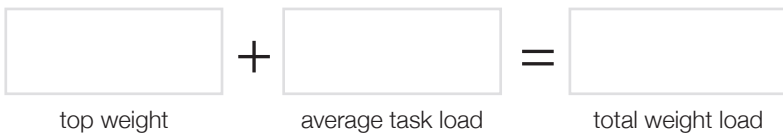

**WEIGHT LOAD**

- 15 - 34 Lbs
- 35 - 60 Lbs
- 61 - 80 Lbs
- 81 - 105 Lbs

**COLUMN OPTION**

- UL** Light
- L** Light
- M** Medium
- H** Heavy Duty